

Montageanleitung / Manual
Las instrucciones de instalación
Les instructions d'installation
Istruzioni per l'uso / Asennusohjeet

SL 787

Pendelleuchte / Pendant luminaire
 Luminaria colgante / Luminaire suspendu
 Apparecchio a sospensione / Ripustettava valaisin

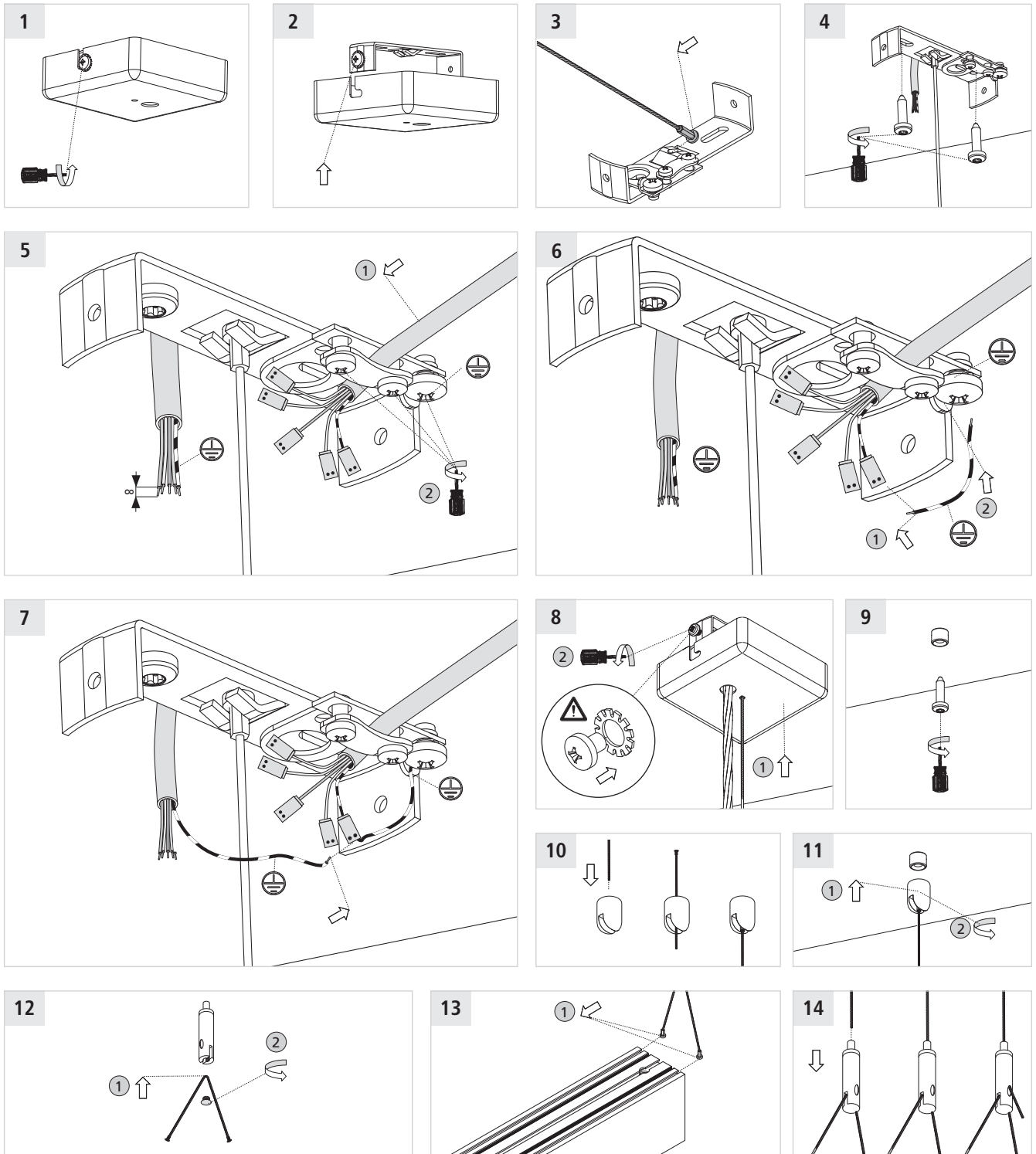

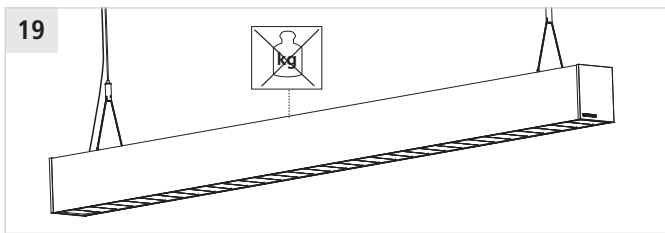
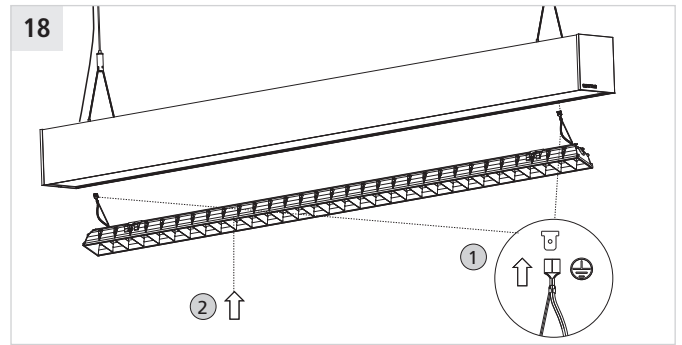
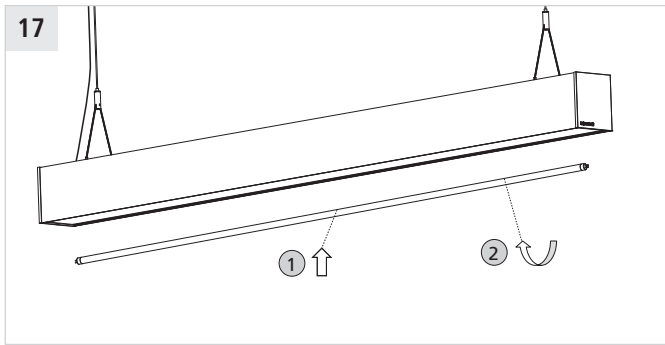
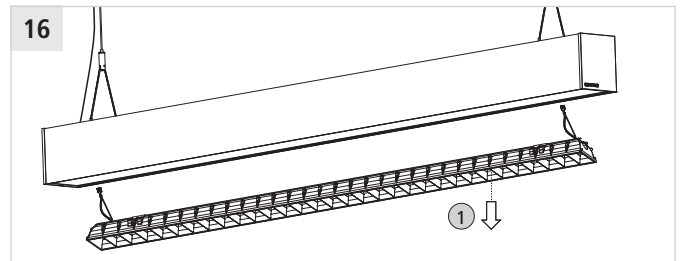
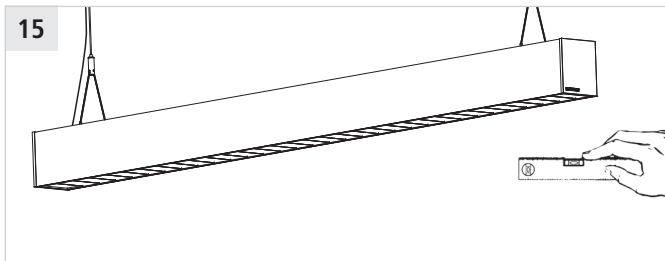

Anschlusschema Wiring scheme

Schéma de raccordement Kytöntäkaavio

EVG

HF ballast

Balasto electrónico

Ballast électronique

Reattore elettronico

HF-liitäntälaite

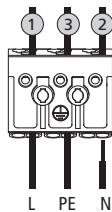

Notlicht mit Batterie

Emergency kit with battery

Equipo de luz de emergencia

Kit di emergenza

Kit éclairage de secours

Turvavaloysikkö

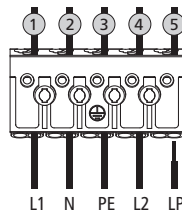

Sensorsteuerung or TouchDIM

Sensor controlled or touchDIM

Commande conduite avec

capteur ou écran tactile DIM

Ilmainen ohjaus tai touchDIM

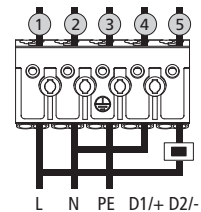

EVG getrennt schaltbar

HF switched separately

Balasto electrónico conmutada por separado

Balasto electrónico commutato separatamente

Ballast électronique commandés séparément

HF-liitäntälaite kytkeä erikseen

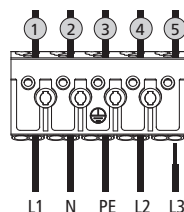

EVG dimmbar (DALI / 1-10V)

HF ballast dimmable (DALI / 1-10V)

Balasto electrónico regulable (DALI / 1-10V)

Ballast électronique graduable (DALI / 1-10V)

Reattore elettronico dimmerabile (DALI / 1-10V)

HF-liitäntälaite himmennettävä

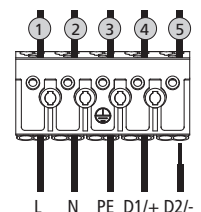

1 Braun / Brown
Marrón / Brun
Marrone / Ruskea

2 Blau / Blue
Azul / Bleu
Blu / Sininen

3 Grün & Gelb / Green & Yellow
Verde & Amarillo / Vert & Jaune
Verde & Giallo / Vihreä & Keltainen

4 Schwarz / Black
Negro / Noir
Nero / Musta

5 Weiß / White
Blanco / Blanc
Bianco / Valkoinen

Information Information

Información Information

Informazioni Tideot

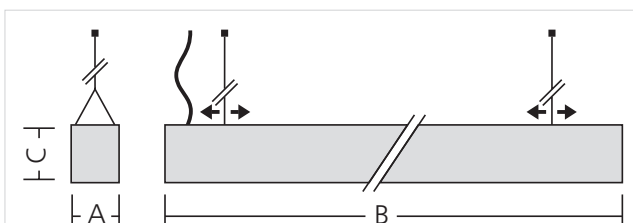

G – Gewicht / Weight / Peso / Poids / Peso / Paino

Pendelleuchte
Pendant luminaire
Luminaria colgante

Luminaire suspendu
Apparechio a sospensione
Ripustettava valaisin

	A	B	C	G
T16 28/54 W	70,5 mm	1192 mm	85 mm	5,0 kg
T16 35/49/80 W	70,5 mm	1492 mm	85 mm	6,0 kg
T16 2x1x 28/54 W	70,5 mm	2378 mm	85 mm	7,0 kg
T16 2x1x 35/49/80 W	70,5 mm	2978 mm	85 mm	8,0 kg